

Azaan International School

Activity sheet V (2019-20)

Grade - II

Sec: _____

Subject- E.V.S

Name: _____

Date: _____

LESSON: 16. MEANS OF TRANSPORT

I. Fill in the blanks.

1. Travelling became easier with the invention of _____. (paper / wheel)
2. _____ moves in the air. (train/ aeroplane)
3. The vehicles used to travel from one place to another are known as means of _____ (communication/transport)
4. _____ burns inside a machine to give it energy to move. (flame /fuel)
5. The full form of CNG _____. (Compressed Natural Gas/ Combustable Natural Gas)
6. Air transport is the fastest and the _____ means of transport. (cheap / expensive)

II. Write True or False.

1. Planting trees also helps to reduce noise pollution. []
2. Air travel is the fastest way to go anywhere. []
3. Ships and boats move on tracks. []
4. Traffic jams happen when there are too many vehicles on road. []
5. Walking or cycling short distances helps in saving fuel. []
6. Large cities have less vehicles than villages. []
7. Anything that produces heat or power when burnt is called as fuel. []

III. Name the vehicles and write its mode of transport.

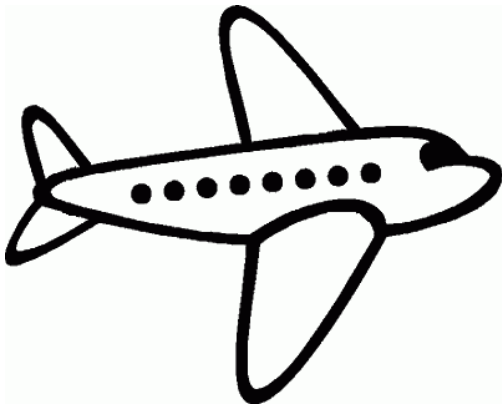
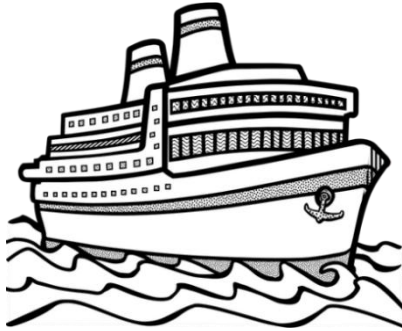
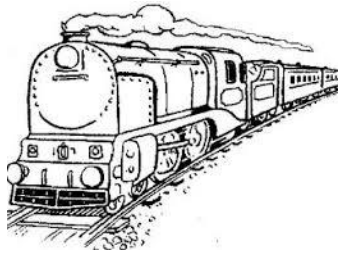

IV. Identify the different types of vehicles. Write(S) for slow vehicles, (F) for fast vehicles and(VF) very fast vehicles for the following.



()

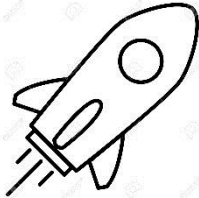

()



()



()



()

V. Name the vehicles with:

a. Two wheels: 1. _____ 2. _____

b. Three wheels: 1. _____ 2. _____

c. Four wheels: 1. _____ 2. _____

d. Many wheels: 1. _____ 2. _____

e. No wheels: 1. _____ 2. _____

Azaan International School

Activity sheet V (2019-20)

Grade - II

Sec: _____

Subject- English



Name: _____



Date: _____

Lesson :11 Ismat`s Eid



VOCABULARY

I. Write the opposites for the words.

1. big  x _____ 

2. tall  x _____ 

3. hot  x _____ 

4. heavy  x _____ 

5. full  x _____ 

II. Complete the sentences using correct homophones.

see/ sea

sun/ son

won/one

week/ weak

eight/ ate

1. A. The crabs were crawling near the _____.
B. I _____ a beautiful scenery on the way.
2. A. The _____ rises from the east.
B. My _____ got a gold medal.
3. A. I have only _____ pencil.
B. My friend _____ the first prize.
4. A. I am going to my relatives house for a _____.
B. I am feeling _____ today.
5. A. He _____ all my chocolates.
B. He bought _____ chocolates for me.

GRAMMAR

III. Use the joining words (and, or, but) to combine the sentences.

1. Let's go to the bakery. Let's buy a chocolate cake.

⇒ _____

2. John loves to watch movie. John loves to eat popcorn.

⇒ _____

3. My mother likes to bake a cake. My mother likes to bake some cookies for the party tonight.

⇒ _____

4. We reached the station on time. The train arrived late.

⇒ _____

5. I love to play cricket. My father loves to play football.

⇒ _____

6. My mother will go to the market. I will go to the market.

⇒ _____

Azaan International School

Activity sheet V (2019-20)

Grade - II

Sec: _____

Subject- Hindi

Name: _____

Date: _____

I. नीचे दिए गए उदाहरण के अनुसार तुकबंदी कीजिए -

जैसे - गल्ला , बल्ला , मल्ला

१. धक्का -

२. मुन्ना -

३. ठप्पा -

४. रस्सी -

II. नीचे दिए गए वाक्य को पढ़कर दिए गए स्थान में दोबारा लिखिए -

१. धारा बहती धीरे - धीरे ।

२. थोड़ी नहीं बड़ी देर से ।

३. टोपी टेढ़ी है । सीधी पहन ।

४. दुबले को दो दूध का दान ।

III. नीचे दिए गए कविता को पढ़कर दिए गए स्थान में दोबारा लिखिए -

शेर चीता घोड़े हाथी

जंगल में रहते सब साथी ।

लोमड़ी भेड़िया और सियार

एक दूसरे के सब यार ।

पेड़ न काटो इनके घर के

करना इन सबसे तुम प्यार ।



Azaan International School

Activity sheet V (2019-20)

Grade - II

Sec: _____

Subject- Math

Name: _____

Date: _____

Chapter- 13 Measuring Weight

I. Look at the balance and write 'H' for heavy and 'L' for light things. And also draw arrow to show the heavier one.

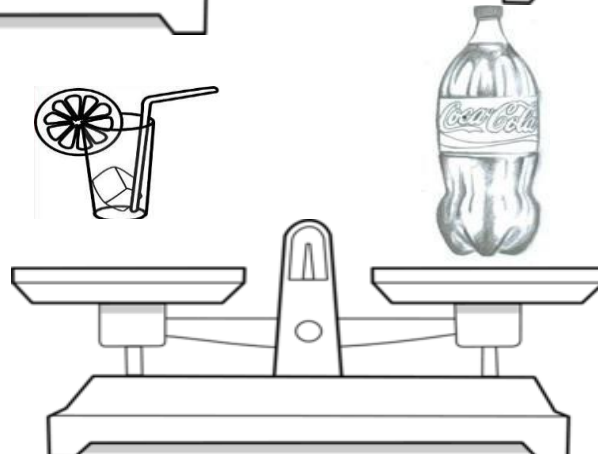
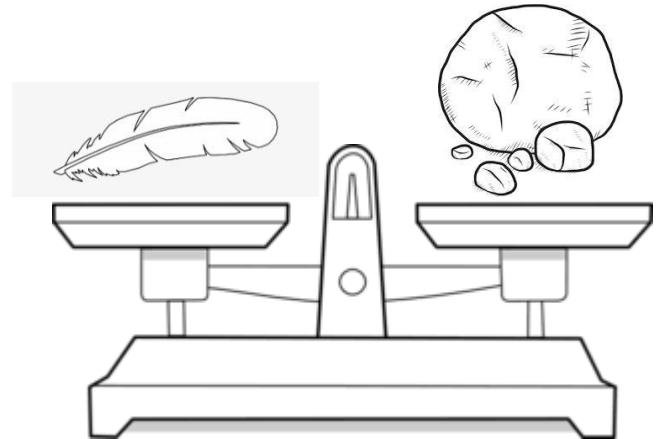
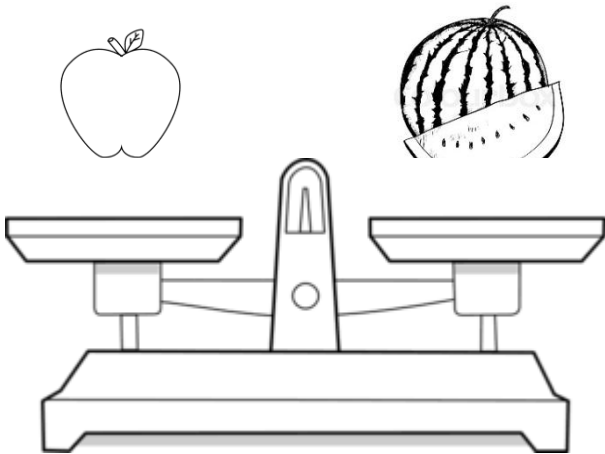
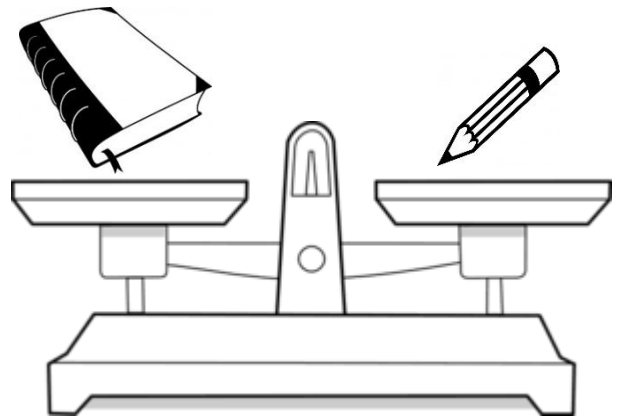
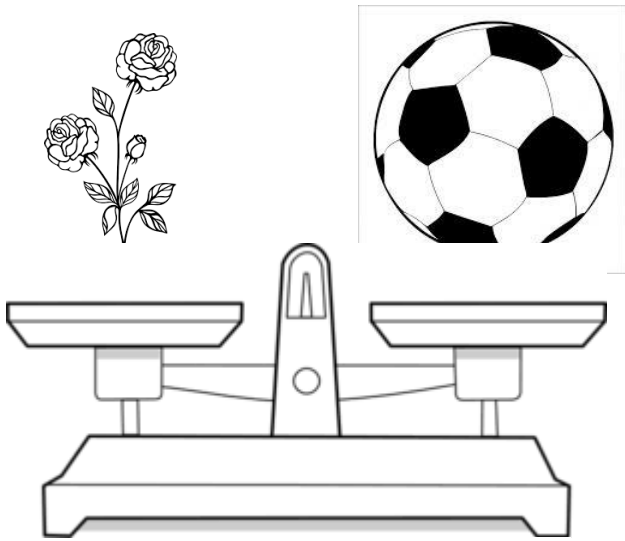

II. Word Problems

1. Two slices of bread weighing 65 gms and 18 gms of cheese was used to make a sandwich . What will be the total weight of the sandwich?

Two slices of bread	gms
Cheese used to make sandwich +	gms
Total weight of the sandwich	gms

The sandwich is of _____ gms.

2. Shanti bought a pineapple weighting 93 gms. If 37 gm of pineapple was eaten away by Arun. How many grams of pineapple is left with Shanti now?

Pineapple bought by Shanti	gms
Pineapple eaten by Arun -	gms
Pineapple left with Shanti	gms

Shanti is left with _____ gms of pineapple.

3. A fruit basket has 52 gms of apples, 19 gms of grapes and 24 gms of mangoes in it. What is the weight of all the fruits kept in the basket ?

Apples in the basket	gms
Grapes in the basket	gms
Mangoes in the basket +	gms
Total weight of all the fruits	gms

There are _____ gms of fruits in the basket.

4. Ravi had 54 gms of sweets. After adding some more sweets. He had 98 gms of sweets in his box. How many grams of sweets did Rahul add in his box?

Total sweets in the box	gms
Sweets Ravi had in the box from before	gms
Sweets added in the box	gms

Ravi added _____ gms of sweets in the box.

5. There are two Mynahs in a garden. One mynah is of 43 gms and the other mynah is of 56 gms. What is the total weight of the two Mynahs altogether?

Weight of one Mynah	gms
Weight of another Mynah	gms
Total weight of two Mynahs altogether	gms

The two Mynahs weighed _____ gms altogether.

Azaan International School

Activity sheet V (2019-20)

Grade - II

Sec: _____

Subject- Urdu

Name: _____

Date: _____

I- تصویر دیکھ کر جملے لکھیے:-

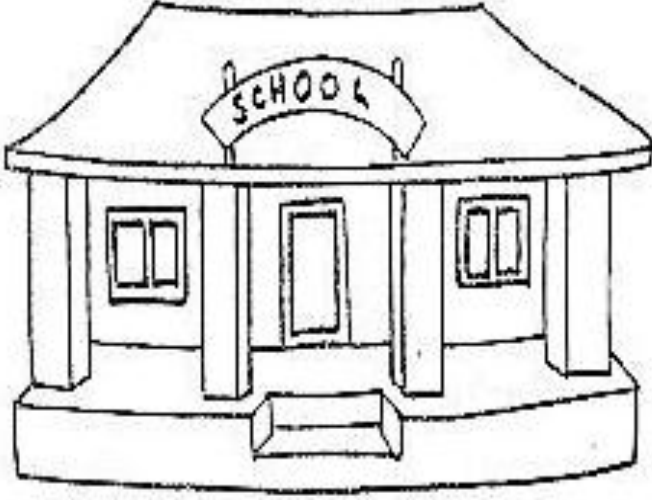

II - ۶

۱ - ۳

۲- آج بہت گرمی ہے۔

۳- وہ کون ہے؟

۴- یہ بلی کالی ہے۔

۵- ام پیلا ہے۔

III- دئیے مذکر الفاظ کو ان کی جمع سے جوڑ ملائیے:-

جھولے

ڈبّہ

جالے

مرغا

گھوڑے

جھولا

ڈبّے

گھوڑا

مرغے

جالا

IV- دئیے گئے الفاظ کی ضد لکھیے:-

۱- گویا

۲- اچھا

۳- ہنسنا

V- دی گئی تصویروں کے نام ڈھونڈ کر لکھیے:-

(پھول ، بارش ، ہریالی ، مور ، دنیا ، بھیا ، چھتری ، پانی)

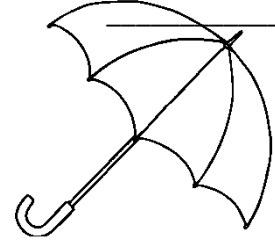
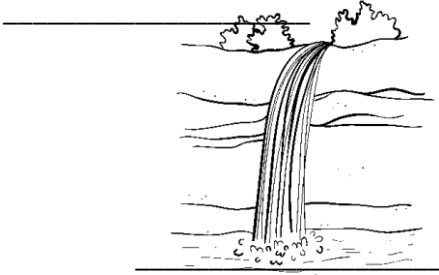
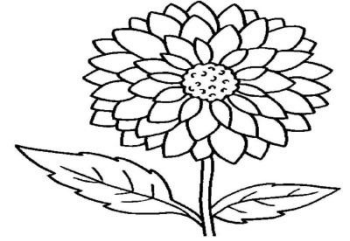
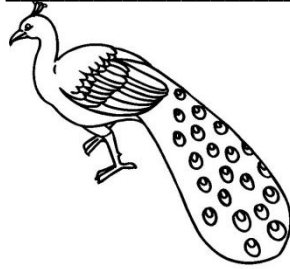
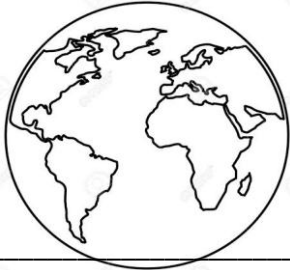

* *